

WELDING PROCEDURE QUALIFICATION RECORD (WPQR)

LEVEL 2

N. 2017NAPO538/5

Manufacturer **UNITEk (ANGRI-SALERNO)**

WPQR No. **U03/2017**

Dated
29.01.2017

Manufacturer's welding procedure (WPS) No. **U03/2017**

Dated **29.12.2017**

RANGE OF QUALIFICATION

Welding process	141	Type	Manual
Joint type	Pipes and branch connections with angle over 60° BW ssnb-ssmb-bs/FW 141		
Single/Multiple pass	Multiple 141	(Impact properties not applied)	
Parent material group(s)	8-8	ISO/TR 15608; ISO/TR20172; ISO/TR 20173; ISO/TR20174	
SUBGROUP ONLY 8.1			
Parent material thickness (mm)	Butt Joint = 1.38 to 5.55	Fillet Joint	$t_1 = \mathbf{1.93 to 5.54}$ $t_2 = \mathbf{1.93 to 5.54}$
Throat thickness (mm)	no restrictions		
Weld deposit thickness (mm)	1,38 to 5.55		
Outside pipe diameter (mm)	≥21,08		
Filler metal make	N.A.	Nr. of wires for process 12: N.A.	
Flux make	N.A.	Flux Designation: N.A.	
Filler metal designation	Solid rod AWS A 5.9 : ER316L		
Shielding gas (ISO 14175)	II	Backing gas (ISO 14175)	I, N, R
Type of welding current	DCEN	Heat Input KJ/cm	No Restrictions
Welding position	ALL POSITIONS EXCEPT PG, PJ ,AND J-L045		
Transfer Mode	N.A.		
Preheat min. (°C)	10 (if ISO/TR 17671-2 requirements are fulfilled)	Interpass temp. Max. (°C)	-
Interpass temp. Max. (°C)	150	Postheat min. (°C)	N.A.
Post weld heat treatment / Ageing	N.A.	Time (minutes)	-
Other information	-		
Welder's/Operator's name	CAROTENUTO WALTER	Stamp No.	CW
Welding test conducted by	UNITEk (ANGRI-SALERNO)		
Mechanical test conducted by	A.Q.C. LABORATORY	Laboratory test No.	18/004 G,H,I
At presence of RINA Surveyor	MARCO BUONOCORE		

We confirm that statements in this record are correct and that the test welds were prepared, welded and tested and have fulfilled the requirements in accordance with **UNI EN ISO 15614-1: 2017** Standard

Issued at: Genova on 27/04/2018



RINA Services S.p.A.

RECORD OF WELD TEST

JOINT DETAILS AND WELDING SEQUENCES									
PIPE TO PIPE SINGLE- V BUTT JOINT ; ONE SIDE WELDING WITHOUT BACKING									
Pass No.	Process	Filler metal diam. (mm)	Amps	Volt	Type of Current/ Polarity	Travel speed (cm/min)	Heat input (kJ/cm)	Metal Transfer mode	Other
1	141	2.4	53	10	DCEN	5	3.8	N.A.	
2	141	2.4	60	11	DCEN	6	3.9	N.A.	

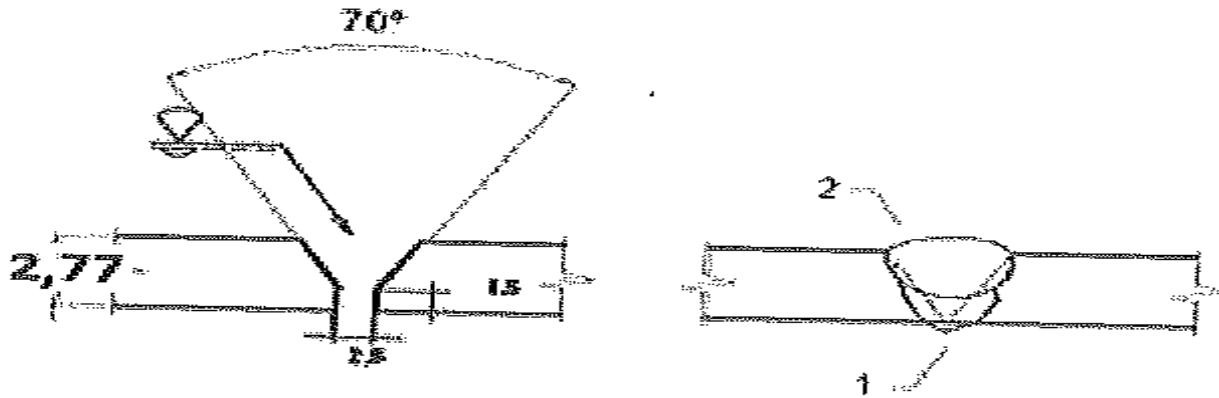

PARENT MATERIAL	
Material specification	ASTM A 312-16a
Type or grade	TP316L
Group(s)/Subgroup(s) No. (ISO/TR 15608; ISO/TR20172; ISO/TR 20173; ISO/TR20174)	8.1
Thickness (mm)	2.77
Throat thickness (mm)	-
Diameter (mm)	42.16
Branch connection angle	N.A.
Other	-

WELDING CONSUMABLES	
Process	141
Trade name(s)	SOGES
Specification	AWS A 5.9
Classification / designation	ER 316L
Size (mm)	2.4
Deposited metal thickness	-
Groove	2,77 mm
Throat	N.A.
Flux trade name	N.A.
Consumable insert	N.A.
Other	-



Certificate No.

GAS			
	Gas	Mixture	Flow rate (l/min.)
Shielding	Ar 99%		9
Trailing			
Backing	Ar 99%		7

POSITION	
Welding position	HL045
Other	-

PREHEAT		POSTWELD HEAT TREATMENT	
Preheat temperature	10 °C	Temperature	N.A. Time -
Interpass temperature	150°C	Method	-
Postheat temperature	N.A. Time -	Other	-

ELECTRICAL CHARACTERISTICS			
Current	DCEN		
Ampere (range)	See table	Volts (Range)	See table
Mode of metal transfer	N.A.		
Tungsten electrode size and type	2.4 mm ; EN ISO 6848 W 20		
Pulse welding details	N.A.		
Plasmawelding details	N.A.		
Waveform controlled welding machine	N.A.	Waveform control mode	N.A.
Power source	LINCOLN INVERTER 270SX	Welding mode	Pulse <input type="checkbox"/> Non pulse <input checked="" type="checkbox"/>
Other			

TECHNIQUE	
Travel speed (range)	See table
String or weave bead	STRING Maximum width of run -
Oscillation (*)	N.A. (Amplitude/Frequency/Dwell time)
Method of groove/edge preparation	Machining/Grinding
Interpass cleaning	Grinding/Brushing
Method of back gouging	N.A.
Orifice or gas cup size	8 mm
Distance contact tube/workpiece (*)	3-5 mm
Multiple or single pass	MULTIPLE
Multiple or single electrodes	SINGLE
Torch angle (*)	N.A.
Other (*)	for fully mechanized/robotic only



TRANSVERSE TENSILE TEST (A.Q.C. REPORT 18/004 I. PAGE 1/2)

Spec. (No.)	Width (mm)	Thickness (mm)	Area (mm ²)	Total load (N)	R _m (N/mm ²)	Fracture location
DC-1	6.42	1.93	12.39	9000	726	Ductile fracture out of weld
DC-2	5.95	1.99	11.84	7850	663	Ductile fracture out of weld

BEND TEST (A.Q.C. REPORT 18/004 I, PAGE 1/2)

Type	No.	Bend Angle	Result
FACE TRANSVERSE (TFBB)	2 OFF	180°	Acceptable
ROOT TRANSVERSE (TRBB)	2 OFF	180°	Acceptable

OTHER TEST

MACROGRAPHIC EXAMINATION **Acceptable**
MICROGRAPHIC EXAMINATION **Not required**

NON DESTRUCTIVE EXAMINATION

VISUAL EXAMINATION **Acceptable**
RADIOGRAPHIC EXAMINATION **Acceptable**
PENETRANT TEST **Acceptable**
MAGNETIC PARTICLE **Not required**
ULTRASONIC TEST **Not required**

Issued at: Genova on 27/04/2018



RINA Services S.p.A.